

AS equipment for capacitor discharge stud welding

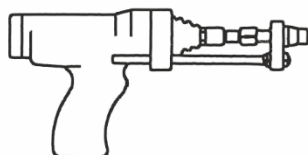

Made in Germany

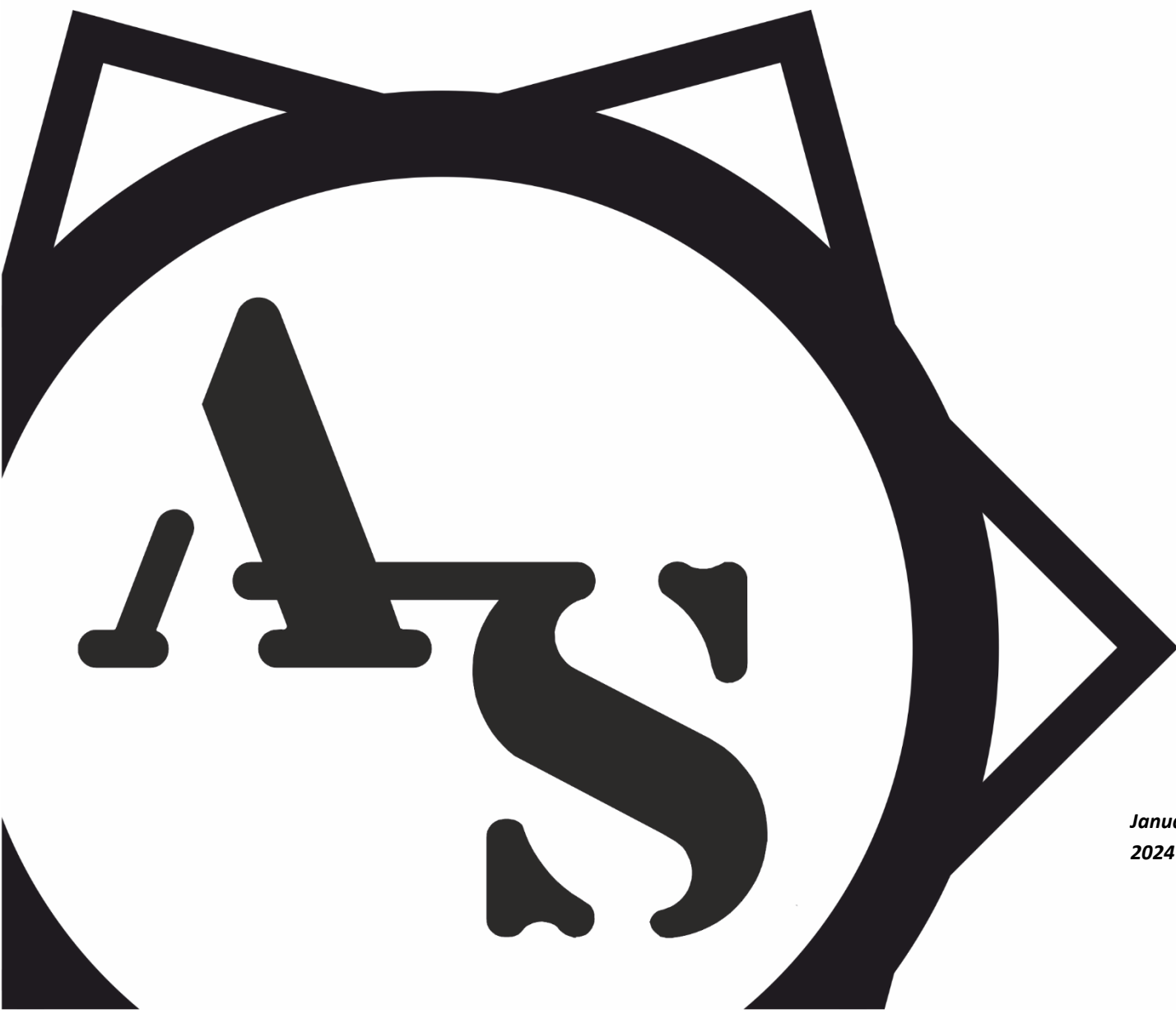

*January. 08.
2024*

Table of contents



<u>1</u>	<u>CHUCK</u>	<u>2</u>
<u>2</u>	<u>GUN ATTACHMENTS</u>	<u>4</u>
2.1	SUPPORTING TUBES	4
2.2	HOLDING RINGS AND EQUIPMENT.....	5
<u>3</u>	<u>CATHODIC PROTECTION ATTACHMENT.....</u>	<u>7</u>
<u>4</u>	<u>CENTERING DEVICES.....</u>	<u>10</u>
<u>5</u>	<u>CHUCKS FOR INSULATION APPLICATION</u>	<u>11</u>
<u>6</u>	<u>PRESSURE DEVICE</u>	<u>12</u>
<u>7</u>	<u>ACCESSORIES FAST WORKING.....</u>	<u>13</u>
<u>8</u>	<u>ACCESSORIES BOLT TESTING</u>	<u>14</u>
<u>9</u>	<u>BEND TEST TOOLS</u>	<u>15</u>
<u>10</u>	<u>EQUIPMENT FOR EARTH.....</u>	<u>16</u>
<u>11</u>	<u>SPARE PARTS</u>	<u>17</u>
11.1	UNION NUT CD.....	17
11.2	BELLOWS.....	17
11.3	INSULATING RING	17
<u>12</u>	<u>OTHER</u>	<u>18</u>

AS Schweißtechnik GmbH
Wullener Feld 48
58454 Witten
info@bolzenschweissen.de
Tel. +49 2302 95640-0

1 Chuck

Our range of chucks offers a variety of applications in the field of tip ignition. Chucks are used to hold the welding stud in the welding gun and are adjustable to the appropriate stud length between 0 and 40mm. **For studs with lengths beyond 40mm, the gun attachment must be extended.** Options for extensions can be found under gun attachments. Furthermore, when selecting the suitable chuck, the stud mounting diameter must be taken into account. Our stud chucks with a 10 mm diameter are compatible with most manufacturers.



Images

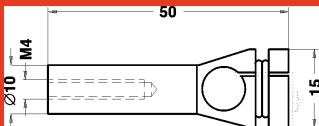
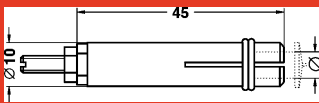
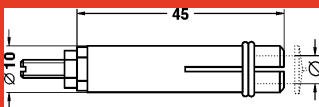

Art. Number

Description

Equipment for

- 082 50 025 Chuck CD Ø2,5mm O-ring copper
- 082 50 003 Chuck CD Ø3mm O-ring copper
- 082 50 004 Chuck CD Ø4mm O-ring copper
- 082 50 005 Chuck CD Ø5mm O-ring copper
- 082 50 006 Chuck CD Ø6mm O-ring copper
- 082 50 071 Chuck CD Ø7.1mm O-ring Copper
- 082 50 008 Chuck CD Ø8mm O-ring copper
- 082 50 010 Chuck CD Ø10mm O-ring copper



- 183 50 003 Chuck CD Ø3mm O-ring Brass
- 183 50 004 Chuck CD Ø4mm O-ring brass
- 183 50 005 Chuck CD Ø5mm O-ring brass
- 183 50 006 Chuck CD Ø6mm O-ring brass
- 183 50 008 Chuck CD Ø8mm O-ring brass
- 183 50 010 Chuck CD Ø10mm O-ring brass



- 182 50 003 Chuck CD Ø3mm metal ring
- 182 50 004 Chuck CD Ø4mm metal ring
- 182 50 005 Chuck CD Ø5mm metal ring
- 182 50 006 Chuck CD Ø6mm metal ring
- 182 50 008 Chuck CD Ø8mm metal ring



M10 chucks need a spacer ring of 7 mm

- 082 50 050 Chuck CD 6,3mm flat plugs Copper



- 082 50 053 Chuck CD 6.3 flat plugs 135° Copper



Matching to our new product. The 135° flat plug. There is now the matching chuck available.

Requires: 17mm wrench (not the normal socket wrench)

Images



Assortment plate chuck CD small



Art. Number	Description
080 40 081	Chuck extension by 10mm (standard)
080 40 080	Chuck extension by 23.5mm
180 40 079	Chuck extension by 55.5mm

Equipment for centering attachment or extension when welding plane is below attachment point

082 50 065	Chuck CD Ø5mm Long O-Ring Copper
082 50 066	Chuck CD Ø5mm Long O-Ring Copper

Corresponds to a chuck extension standard. This chuck is mostly used in conjunction with the centering device

000 00 260	With the tip ignition assortment plate, untidy drawers are history. You will receive a full equipped assortment plate with 7 standard chucks for welding with the tip ignition procedure. The assortment plate is made of stainless steel and provides the matching studs to easily and quickly storage.
------------	--

Included are:

- 1x stainless steel assortment plate
- 1x 8250003 Chuck tip ignition M3
- 1x 8250004 Chuck tip ignition M4
- 1x 8250005 Chuck tip ignition M5
- 1x 8250006 Chuck tip ignition M6
- 1x 8250071 Chuck tip ignition Ø7.1
- 1x 8250008 Chuck tip ignition M8
- 1x 8250050 Chuck flat plug

Equipment for



2 Gun attachments

2.1 Supporting tubes

Our range of gun attachments offers a variety of applications. Generally, our gun attachments are used for the straight positioning of the welding stud. Our gun attachments are compatible with many welding guns on the market. **Please pay attention to the length and mounting diameter.** The lengths deviating from the standard are used for extension in stud applications beyond 40mm



Images

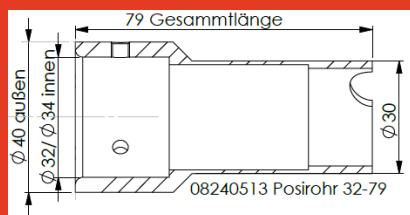

Art. Number	Description	Equipment for
082 40 513	Positioning tube i32x79 mm standard	1803 1901 2902
182 40 011	Positioning tube i32x90 mm	
082 40 008	Positioning tube i32x95 mm	
082 40 010	Positioning tube i34x79 mm standard	1802
182 40 512	Positioning tube i34x90 mm	
082 40 009	Positioning tube i34x95 mm	
082 40 013	Positioning tube i34x64mm hortened	1804

The posi tube is used to position the gun and the welding stud straight on the workpiece. It also avoids the flying sparks. It is possible to work in sheet metal templates with a hole diameter of 30mm.

082 40 015	Noise protection tube i32x79 mm Al	1803 1901
082 40 012	Noise protection tube i34x79 mm Al	1802
082 40 014	Noise protection tube i34x64mm shortened	1804

The sound insulation tube has a sound-absorbing effect in addition to the normal support functions. This item is recommended for customers who have very noisy welding processes in their application, such as the application of release agent. It also avoids flying sparks











182 40 532	shielded gas tube Øi32x79 offset	2902
182 40 534	shielded gas tube with hose	

The shielding gas tube, in addition to the normal support function, has the possibility to use the shielding gas function of our studwelder. It also avoids the flying sparks

2.2 Holding rings and equipment

Images



Art. Number	Description	equipment for
180 40 373	Holding ring iØ32 mm	  
<p><i>The foot ring with matching feet also fulfills the support function for straight positioning. Unlike the support tube, the workpiece can be seen exactly at the welding point.</i></p>		
180 40 050	Holding ring iØ34 mm	
180 40 706	Holding ring iØ34 mm shortened	
180 40 049	Foot CD 6x49mm M4	Holding ring 180 40 373
180 40 060	Foot CD long 6x76,5mm M4 (foot for longer studs)	Holding ring 180 40 050 Holding ring 180 40 706
092 40 010	Spacer ring 15 mm	Holding ring 180 40 373 Holding ring 180 40 050 Holding ring 180 40 706
<p><i>The intermediate ring is used to extend the foot ring with feet for bolt lengths > 40mm and is mounted between the foot ring and feet. It can be used several times on top of each other and extends each 15mm .</i></p>		
092 40 009	Spacer ring 7mm for extension by using M10 chucks	Holding ring 180 40 373 Holding ring 180 40 050 Holding ring 180 40 706
080 40 145	Holding ring TK38 i Ø32 mm	  
<p><i>The foot ring with matching feet provides increased stability and safety</i></p>		
080 40 143	Holding ring TK38 I Ø34 mm	 



080 40 077 Foot conical $\varnothing 10 \times 41$ mm TK38 M5

Holding ring 80 40 145

Holding ring 80 40 143

3 Cathodic protection attachment

The cathodic protection attachment is ideal for purposes where working with conventional ground clamps is not possible or only possible to a limited extent. It is particularly often used for welding on round surfaces, such as cathodic corrosion protection on gas pipes. It has a diameter of 40mm at the front of the ground ring. It can be minimally welded on pipes with \varnothing 15mm with this attachment.



Images



To the product video

POS 2



POS 1



Art. Number	Description	Equipment for
080 10 001	Cathode protection attachment i34	1802

080 10 004	Cathode protection attachment i32	1803
------------	-----------------------------------	-------------

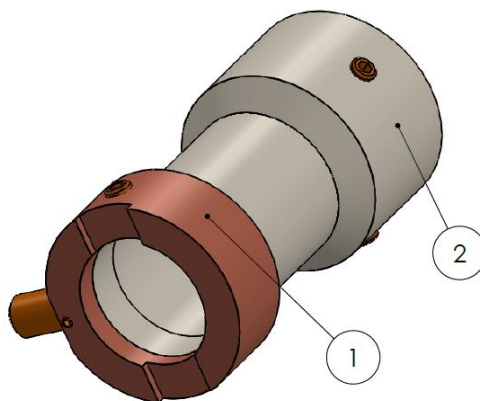

082 40 080	Positioning tube i34x74 for cathodic protection	Cathodic protection attachment 080 10 001
------------	---	---

082 40 081	Positioning tube i32x74 for cathode protection	080 10 004
------------	--	------------

080 10 000	Earth ring for cathode protection	Cathodic protection attachment 080 10 001 080 10 004
------------	-----------------------------------	--



New innovation **AS K22**

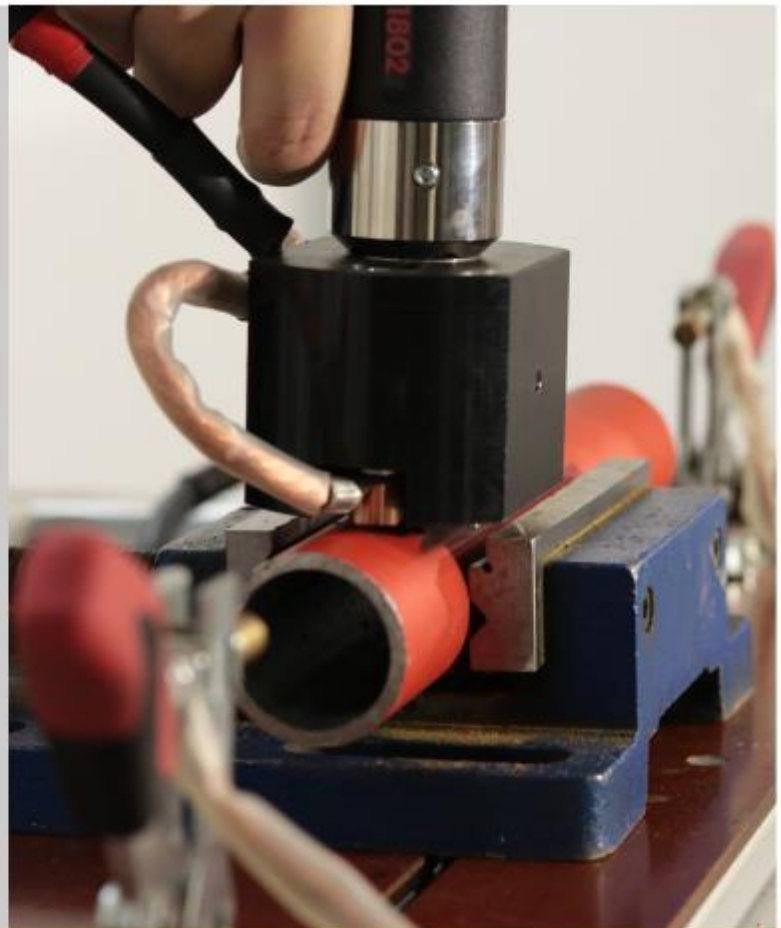

From now on there is a new variant of cathodic protection welding. The K22 has an ew advanced system to achieve a higher welding quality and less abrasion.



Images



To the product video

Art. Number	Description	Equipment for
080 10 055	Cathodic protection attachment K22 i34 springy	
080 10 005	Cathode protection attachment K22 i32 springy	
080 10 008	Electrode cathode protection attachment K22	Cathodic protection attachment 080 10 055 080 10 005

4 Centering devices

The centering device enables even more precise centering option than the positioning tube. The centering tube and the chuck can be precisely centered by aligning them. Centering errors between stud and tube attachment can be avoided. Different diameters can be combined



Images



Pos 4



Pos 5



Pos 6

Pos 3

Pos 2

Art. Number	Description	equipment for
092 40 011	Centering device PiØ34, centering Ø30	1802
092 40 012	Centering device PiØ34, centering Ø26	
092 40 014	Centering device PiØ34, centering Ø20	
092 40 015	Centering device PiØ32, centering Ø30	1803 1901 2902
092 40 016	Centering device PiØ32, centering Ø26	
092 40 018	Centering device PiØ32, centering Ø20	
080 40 082	Centering tube 20 mm	Centering device
080 40 086	Centering tube 26 mm	
080 40 083	Centering tube 30 mm	
080 40 092	Centering cup with dowel pin Drm 20mm	
080 40 096	Centering cup with dowel pin Drm 26mm	
080 40 093	Centering cup with dowel pin Drm 30mm	
080 40 094	Dowel pin 10x80mm	Centering device
080 40 138	Holding plate	Centering device
080 40 067	Spacer 10x17 TK38	Centering device

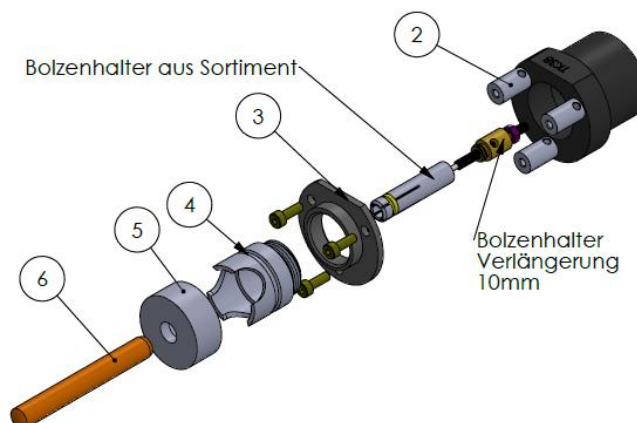

5 Chucks for insulation application

The stud holders for insulating application are especially suitable for welding isonails. Furthermore, the magnetic stud holder offers the possibility to weld plate pins quickly and easily due to its magnetic effect.



Images



Maximum pin length for AS 1802 without stand attachment 115mm. Other guns differ.

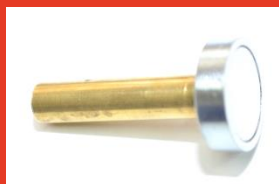

Art. Number	Description	equipment for
825 00 21	Chuck CD 2 ISO O-ring length Iso.pin	1802
825 00 31	Chuck CD 3 ISO O-ring length Iso.pin	1803 1804
		1811 1901
182 50 027	Magnetic Chuck M10 mount internal thread Ø25 Super magnet	1810
182 55 027	Magnetic Chuck M10 mount internal thread Ø34 copper plate	1810
182 50 127	Magnetic Chuck Ø10 mount Ø25 Super magnet	1811
182 55 127	Magnetic Chuck Ø10 mount Ø34 copper plate	1811
182 00 027	Copper plate with screw and washer (spare part)	Magnetic Chuck 18255027 18255127

6 Pressure device

Images



Pos 1

Pos 2

Pos 3

Art. Number	Description	Equipment for
	Pressure device for plate pin welding	
19710020	Pressure ring/ pressure plate	Pressure device
19710022	Pillar $\varnothing 10 \times 36$	Pressure device
19710023	Holding plate	Pressure device

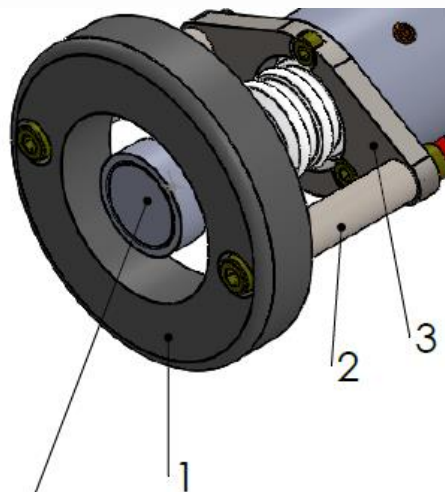

Magnet Bolzenhalter

7 Accessories fast working

For fast and accurate work, the gun stand is recommended in manual mode.

Images



Art. Number	Description	Accessories for
000 00 350	pistol stand with manuel drive incl. adapter	suitable for all pistols with holding ring

The gun stand enables precise alignment of the gun to workpieces in a fixture

Pneumatic or manual clamps for mass transfer on request depending on the application.

180 50 190	Foot switch	for automatic processes
------------	-------------	-------------------------

8 Accessories bolt testing

Tool for non-destructive 100% inspection of studs in difficult welding applications such as aluminum and special materials.



Images



Art. Number	Description	Equipment for
085 00 000	Torque tester unit without torque wrench with adapter & tools	All welding studs between Ø3- Ø6 and Ø8
085 000 01	Torque wrench 2-12Nm 1/4"	8500000 Torque testing unit
085 000 02	Torque adapter piece for long studs	8500000 Torque testing unit
085 000 03	Torque test insert Ø3	8500000
085 000 04	Torque test insert Ø4	Torque testing unit
085 000 05	Torque test insert Ø5	
085 000 06	Torque test insert Ø6	
085 000 08	Torque test insert Ø8	
085 000 09	Assortment box 9 compartments torque test	8500000 Torque testing unit

9 Bend test tools

Tool for quick execution of work samples for destructive strength testing before starting work, or for spot checks

Images

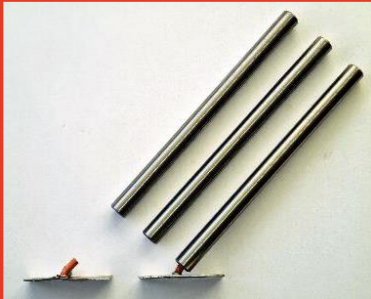

Art. Number	Description	Equipment for
085 00 023	Bending test tool 195mm for studs Ø3	All welding studs between Ø3- Ø8
085 00 024	Bending test tool 195mm for studs Ø4	
085 00 025	Bending test tool 195mm for studs Ø5	
085 00 026	Bending test tool 195mm for studs Ø6	
085 00 027	Bending test tool 195mm for studs Ø7	
085 00 028	Bending test tool 195mm for studs Ø8	

10 Equipment for earth

Images

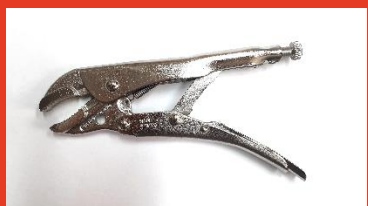

Art. Number	Description	Equipment for
192 40 013	Earth cable 2,5m 25qmm complete with grip pliers DIX 50qmm plug (spigot diameter of welding cable plug Ø13)	All welding equipment in the range
192 40 016	Earth cable 5m 25qmm complete with grip pliers DIX 50qmm plug (spigot diameter of welding cable plug Ø13)	
	As a special variant also with plug or socket for Ø 9mm on request for older devices or other manufacturers	
193 40 015	Earth cable 5m 50qmm complete with grip pliers DIX 50qmm connector (spigot diameter of the welding cable plug Ø13)	
180 10 062	Grip pliers 10" large	All welding equipment in the range
180 10 061	Grip pliers 7" small	
	Without earth cable	

11 Spare parts

Images

11.1 Union nut CD



**Art.
Number**

80 40 040

Description

Union nut for all CD welding guns and 2902

Equipment for



11.2 Bellows



180 20 013

Bellows for all CD welding guns and 2902



11.3 Insulating ring



180 40 044

Insulating ring with \varnothing 32



080 40 041

Insulating ring with \varnothing 34



180 40 039

Insulating ring AS 1804



Images



Art. Number

Description

Equipment for

092 40 020 Stand CD 190 mm
Gun mount Ø 34mm

The stand is required, for example, when welding iron nails and plate pins. Due to the adjustable length, lengths up to 190mm are achievable



092 40 021 Stand CD 190mm
Gun mount Ø 32mm



180 40 085 Socket wrench CD
To tighten the sleeve/clamping nuts



082 40 011 Angle shaft CD

The angled shaft is ideal for working close to objects where welding with posi tube or stand is not possible

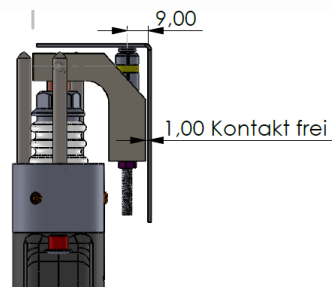

000 00 220 Automatic center punch

Automatic center punching for consistent grit depth for tip ignition studs.

085 00 010 Allen key SW 2.5 L112x18
085 00 011 Allen key SW 3 L126x20
085 00 012 Allen key SW 4 L142x25
085 00 013 Allen key SW5 L160x28



Images



Art. Number	Description	Equipment for
00000215	Case for equipment Inner dimensions 420x275mm	All equipment for all welding guns in our product range